



# Bluebird Restoration Association of Wisconsin

## Informational Packet: Attracting Eastern Bluebirds & other cavity nesters

Pat Ready, BRAW Editor & Designer

### Life cycle of the Eastern Bluebird (*Sialia sialis*) Photos by Patrick Ready.



Pair select box and female builds the nest.



Within a week or two 3-5 eggs are usually laid in the nest.



The male stands guard.



After 13-14 days of incubation the chicks hatch.



After 16-22 days old the chicks are ready to fledge.



The chicks grow quickly being fed by both parents.



**Bluebird Restoration Association of Wisconsin, Inc.** has come a long way since its inception in 1986 with its understanding about how to effectively manage Eastern Bluebirds. This booklet pulls together the collective experiences of people who work especially for the interests of bluebirds, particularly those persons who record and summarize their nest box data and whom we term “monitors.” BRAW’s handling and interpretation of monitor data is done through computer analysis and data entry.

**BRAW is the first to admit** that not every experience with bluebirds is common to all bluebirds in every corner of the state. However much of our knowledge appears to be true regardless of where we encounter bluebirds. But bluebird management can be restricted by climate, geography, and habitat. The presence or absence of one or more natural enemies of bluebirds can alter results or even be a disaster. Nest box design, how a nest box is mounted on a post, and the spacing of boxes can profoundly affect what happens on a bluebird trail.

**It is our hope** that this **Informational Packet** produced by the Bluebird Restoration Association of Wisconsin, Inc. will bring you better understanding about how to succeed in helping this bird “with the sky on its back.”

The Bluebird Restoration Association of Wisconsin, Inc. (BRAW) is a nonprofit organization incorporated under the Laws of the State of Wisconsin. The **purpose and mission** of BRAW is to monitor and increase the production of the Eastern Bluebird and other native cavity –nesting song birds through a coordinated statewide nest box construction and monitoring program. BRAW seeks to expand public knowledge and enthusiasm for the Eastern Bluebird so that a growing number of people will have the desire to aid cavity nesters and have the knowledge about how to best accomplish this in their own communities. BRAW coordinates its cavity nester recovery program through a network of volunteer **county coordinators**, workshops, meetings, and its official **Wisconsin Bluebird** newsletter.

When BRAW was organized in 1986, it was estimated that the Eastern Bluebird population *in its historic range* had declined by 90 percent during the preceding 50 years due to changes in agriculture practices, competition from the House (English) Sparrow and European Starling, severe weather in its central and southern winter ranges, and the loss of nest sites, such as tree cavities and hollow wooden fence posts.

A few far-sighted individuals and local organizations that took note of the plight of bluebirds in their respective communities had helped bluebirds and other cavity nesters during those bleak years. Much experimentation was done to develop nest boxes. Some of those efforts were more successful than others. Bluebird “trails” consisting of a few or many bluebird nest boxes were established by some persons. Special care of nest boxes (monitoring) was begun by more knowledgeable bluebirders. A few individuals kept records by documenting bluebird nesting success and events on their trails.

BRAW works to bring to light the efforts of Wisconsin citizens who had been helping bluebirds in the past and those who have recently joined their ranks. Since 1996, BRAW has entered monitors’ data into a computer database and as a result, through computer analysis of the data, it is gaining better insight into the complexities of how management practices and box design affect bluebird population dynamics.

Through workshops, the Annual State Convention, and publication of research findings in the **Wisconsin Bluebird** newsletter, BRAW shares successful birding techniques while hopefully avoiding some of the mistakes painfully learned by earlier bluebird enthusiasts.

County coordinators are the “grassroots” of Wisconsin’s eastern bluebird restoration program. County coordinators conduct local workshops each year that are usually held in late winter and early spring. BRAW’s county coordinators distribute literature, are sources for nest box construction plans, answer questions, and otherwise serve as knowledgeable persons to help individuals, clubs, and organizations effectively aid bluebirds and other cavity nesting birds. The county coordinators assist interested persons in becoming members of BRAW.

BRAW members provide the financial base for the publication of the quarterly newsletter, **Wisconsin Bluebird**. The newsletter reports monitors’ data and data interpretations, different experiences of readers and other persons who work with cavity nesters, how to recognize good habitat, why and how to monitor a bluebird trail, how to spot natural enemies of bluebirds, how to defend bluebirds against their enemies, how to identify nest failures and what to do about them, about the impact and significance of other bird species that may nest in bluebird nest boxes, the names and addresses of county coordinators and BRAW, Inc. officers and directors.

The newsletter reports monitors’ data and data interpretations and different experiences of readers and other persons who work with cavity nesters. Also, information is given about learning to recognize good habitat, why and how to monitor a bluebird trail, how to spot natural enemies of bluebirds and how to defend bluebirds against their enemies, how to identify nest failures and what to do about them and information about other bird species that might reproduce in your nest boxes. Finally, the names and addresses of the Board of Directors and County Coordinators are listed.

BRAW, Inc. maintains liaisons with the Department of Natural Resources’ Bureau of Endangered Resources, the UW-Stevens Point, the North American Bluebird Society (NABS) and the Wisconsin Society for Ornithology.

We invite you to join us and be a part of the bluebird conservation movement in Wisconsin.

Visit our web site at: [www.braw.org](http://www.braw.org)  
**GUIDELINES FOR SUCCESSFUL MONITORING  
 OF EASTERN BLUEBIRD NEST BOXES**

By

Kent D. Hall, Ph.D., Coordinator,

Data Collection & Analysis, Bluebird  
 Restoration Association of Wisconsin  
 (BRAW)

**Why Monitor Eastern Bluebird Nest  
 Boxes?**

In Wisconsin, Eastern Bluebirds have traditionally never been abundant because good habitat is lacking in the state. But in the late 1960's, 1970's and early 1980's, Breeding Bird Surveys done by the USGS on the same stretches of roadway on a yearly basis, started revealing alarming drops in the few bluebird populations we had (partly due to severe weather in 1976-77 on their overwintering grounds [Davis & Roca 1995]; see Fig. 1). The other three main cavity nesters (chickadees, swallows & wrens) have never shown a similar drop in population.

Armed with this information, the WDNR approached citizen groups around the state to attempt to stimulate an interest in an artificial nest box program to "bring back" this imperiled species. The Bureau of Endangered Resources of the WDNR called a meeting at Schmeeckle

Reserve in Stevens Point in February of 1986 (Don Bragg, WDNR Retired, Personal Communication).

As a result of this meeting, the Bluebird Restoration Association of Wisconsin (BRAW) was formed on March 15, 1986. BRAW has worked to increase the population of this species ever since.

**History of Bluebird Production in  
 Wisconsin by BRAW Monitors.**

There is strong reason to believe bluebird conservation efforts are working. Based on BBS routes, the best estimate of bird populations we have in the state, populations of bluebirds plunged by 60% and hit a low in 1979-1981. (Fig.1) By 2007 (latest date for which data is available), the population had increased by about 229% from these lowest levels and by 45% from 1966 levels.

How much has BRAW contributed to the recovery of the bluebird? Table 1 shows that bluebirds in Wisconsin made a solid comeback from 1980-2007 (+ 4.4%), even better than in North America as a whole (+2.3%). Some, perhaps most of the credit for the resurgence in the bluebird population in Wisconsin compared to the rest of the U.S., can be attributed to the extensive, artificial nest box program implemented by BRAW.

Table 2 and Figure 2 compare BRAW data for the 2005-08 and 1994-2008 periods, respectively. It is obvious that the time period of 2001-2007 was a golden period for bluebird production in Wisconsin. It is thought that two major factors influenced this trend: 1) good weather and 2) implementation of management techniques studied from 1994 to 2001 (nest box location, spacing, predator guards & nest box design).

But in 2008, harsh weather conditions occurred in Wisconsin (cold/wet weather in April & May & heavy rains in June). These conditions contributed to a nest box production lower than



Pat Ready

**Jan 09: This monitoring guide is dedicated to the hundreds of nest box monitors that have collected data for BRAW for the first 23 years of its existence. It is because of their careful collection of data and responsible reporting that it has been made possible.**

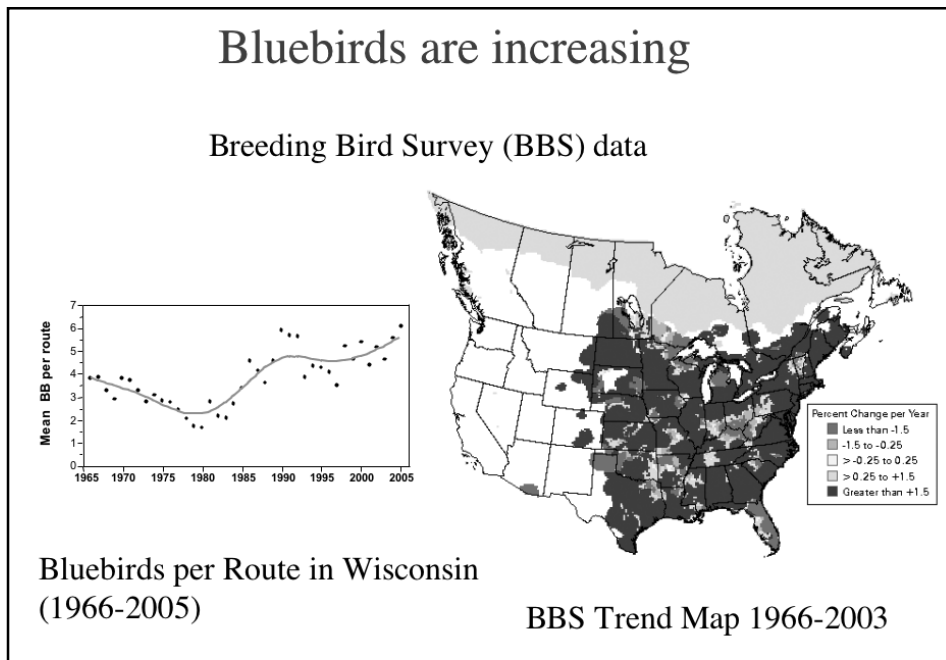

**Figure 1. Breeding Bird Survey (BBS) data - bluebirds are increasing**

any since 2005 (2.9 vs. 2.94 birds per box), 19.4% below the average of 2007. This problem was not related to nest box occupancy (up 6% from 2007), but was related to the fact that bluebirds did not lay as many eggs/nest behavior apparently effected by

weather. Another major contributing factor was the loss of several megatrail reports from 2007--due to illness, death & retirements.

It is obvious that we will never control the weather. But it is not only the weather in Wisconsin that

influences bluebird reproduction in the state. Dr. Peter Dunn has shown (Fig. 3) that colder than normal weather in the over wintering grounds of the Gulf of Mexico states, can suppress reproduction the following spring.

No other cavity nesting songbird is subject to this reproductive influence by the weather. Black-capped Chickadees do not migrate and both Tree Swallows and House Wrens migrate far enough south that weather does not influence their overwintering populations as much. Moreover, Tree Swallows (4 weeks later) and House Wrens (6 weeks later) do not start nesting until much later in the season and are not as subject to harsh weather effects on reproduction as are bluebirds.

Finally, BBS routes show that the populations of other cavity nesters are much higher than bluebirds (Fig. 4). Chickadees have about 2x, Tree Swallows about 3.5x and wrens about 4x the population of bluebirds.

In spite of the good news about bluebird populations in Wisconsin and the U.S., this species continues to be vulnerable to weather and competition from other cavity nesting species. A continuation of conservation efforts is not only desirable, it is essential if we are going to monitor healthy numbers of this charismatic species.

The bluebird trail that I coordinate (since 2002) is sponsored by the Aldo Leopold Audubon Society (ALAS). In 2008 it produced 4,324 bluebirds. In the seven years of its existence, it has produced about 18,070 songbirds (13,837 bluebirds; 3,368 swallows, 518 wrens & 347 chickadees). For the 2009 season, our trail will have about 1,130 nest boxes with 51 monitors responsible for a total of 28 sub-trails.

Each of these sub-trails are monitored weekly and electronic reports sent to me for analysis. These data have contributed considerably to the information found in Table 3 and 4. I thank the dozens of monitors for the ALAS bluebird trail that have contributed to our improved knowledge of bluebird conservation.

**Table 1. Population trends for Eastern Bluebirds and other cavity nesting species in Wisconsin and North America based on Breeding Bird Surveys by the USGS.**

Species	1966-1979: WI	1980-2007: WI	1980-2007: NA
+ EABL	-10.5%	+4.2%	+2.3%
TRES	+3.2%	+0.2%	+0.6%
BCCH	+1.1%	+1.1%	+0.2%
HOWR	+0.6%	+1.0%	+0.2%

\* Populations levels for all NA bird species can be found at: [www.mbr-pwrc-usgs.gov/bbs](http://www.mbr-pwrc-usgs.gov/bbs)

+ EABL = Eastern Bluebird; TRES = Tree Swallow; BCCH = Black-capped Chickadee; HOWR = House Wren

**Table 2. Comparison of Eastern Bluebird and Tree Swallow fledglings in 2005-07**

Year	EBF	EBF/Box	TSF	TSF/Box	Total Boxes	EBF: TSF
2008	21,379	2.9	9,864	1.3	7,387	2.17:1
2007	28,244	3.60	10,051	1.3	7,861	2.81: 1
2006	21,047	3.50	6,574	1.1	6,021	3.20: 1
2005	17,670	2.94	8,440	1.4	6,016	2.09: 1

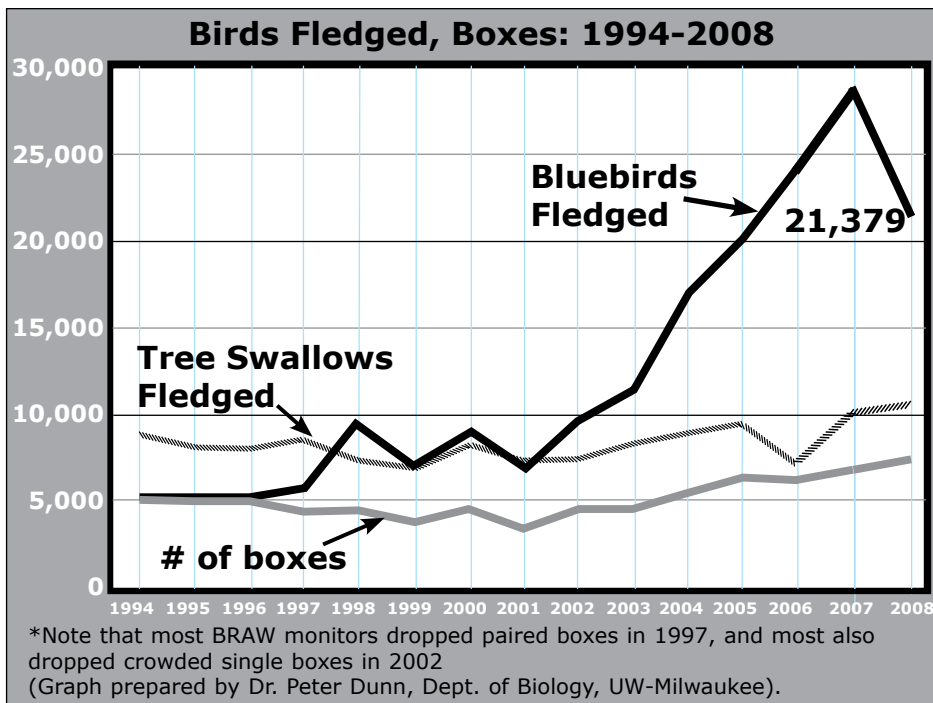

**Figure 2. \*Number of fledgling Eastern Bluebirds & Tree Swallows, and number of nest-boxes presented, from 1994 to 2008.**

Winter weather in the Gulf states affects the number of bluebirds in Wisconsin

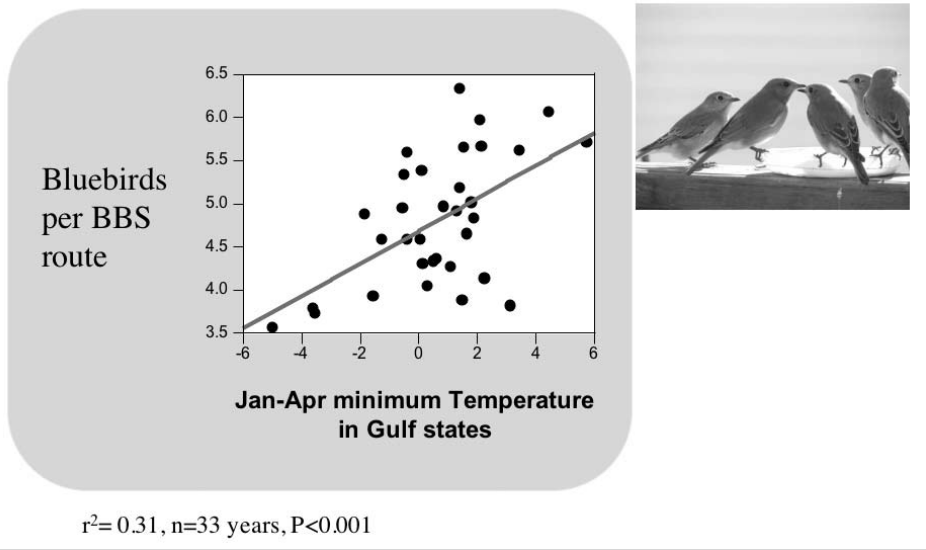

Figure 3. Breeding Bird Survey (BBS) data - bluebirds per route

Relative Abundance of Cavity Nesting Songbirds on Breeding Bird Surveys in Wisconsin for 2006

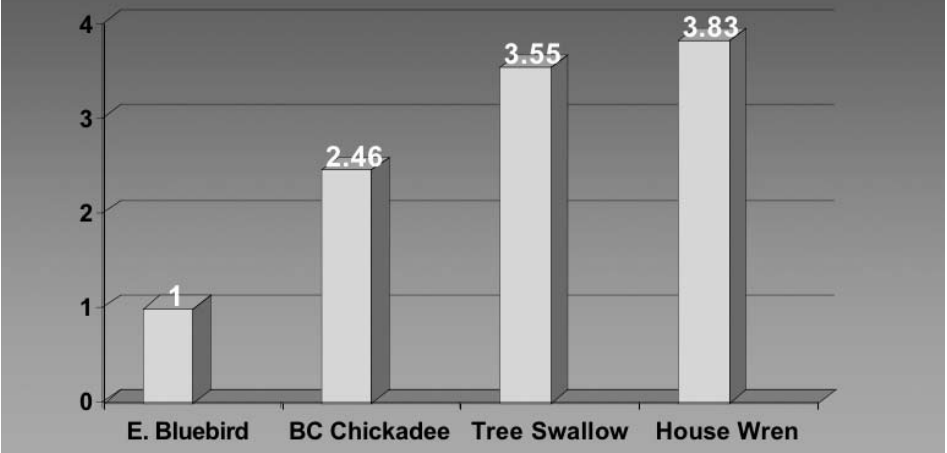

Figure 4. Relative Abundance of cavity nesting songbirds.

Table 3. Reproductive landmarks of songbirds & House Sparrows In the Central Wisconsin area (2005 Data\*)

Bird Species	Arrival Date	1st nest Built	1st egg Laid	1st Hatch	1st Fledge	Last Fledge	Length of Reproduction
EABL	24 Mar	1 Apr	10 Apr	30 Apr	20 May	10 Sept	163 days
BCCH	Resident	7 Apr	18 Apr	5 May	25 May	25 July	110 days
TRES	29 Mar	1 May	12 May	8 June	28 June	21 July	82 days
HOWR	20 Apr	15 May	23 May	20 June	20 July	2 Sept	107 days
HOSP	Resident	1 Apr	10 Apr	DNA	DNA	DNA	# 163 days

\*In some cases, the actual dates may be off by a few days

# Estimated only

Common Myths Associated With Bluebird Monitoring.

There are several myths that monitors must dispel in order to reach a high production output for their boxes:

1) Moderate disturbances will cause bluebirds (and other cavity nesting songbirds) to abandon their nests.

This is so untrue. This myth, very common in the general public, has been used forever by parents and others to keep children from vandalizing nests. It may serve a good function from that standpoint, but beyond that goal, the idea is worthless.

It should first be noted that perching birds (= passerines) can smell but, "residual human scent on eggs and nest does not deter the parental instincts of passerines (Gill 2007)". Their sensory existence is mainly limited to sight and hearing. When one opens a nest box, therefore, and handles the eggs or young, or the adults themselves, the birds are not influenced by smell from the monitor.

In fact, bird banders have captured both adults and young in the nest for decades, taken them out to band them, held them firmly to affix the band and then released (adults) or replaced juveniles in the nests—all with only rare mishaps. And bluebird monitors don't come close to traumatizing juveniles & adults in this way.

Moreover, Audubon monitors have found dozens of starving chicks in nests in '05-'08 and have moved them to other nests with young. In 60 of



**Table 4. BRAW management practices that are thought to have improved Eastern Bluebird production on the Audubon and other Bluebird Trails.**

<p><b>Location, Location, Location:</b></p> <ol style="list-style-type: none"> <li>1) Need a territorial forage area of 1-3 acres of predominantly open habitat</li> <li>2) Ideal sites: short, sparse grass with interspersed trees: cemeteries, golf courses, parks, roadsides, bike trails, RR tracks</li> <li>3) Boxes should be totally exposed to sunlight from sunrise until noon; thereafter, shading is permissible</li> <li>4) <b>Perch sites:</b> <ol style="list-style-type: none"> <li>a) One or more trees (10'+ ideal) right in front or to one side of nest box (most hunting starts on a perch and these trees are vital for use as survival perches when chicks first fledge)</li> <li>b) Fences (barbed, electric, wooden)</li> <li>c) Electrical wires (no more than 30' high preferred), clothes lines</li> </ol> </li> <li>5) Noisy sites okay (interstates, other roadways, railroads, temporary air shows, church picnics)</li> <li>6) Roadways with limited traffic can be ideal nest box sites and adults and young chicks are rarely killed by traffic.</li> </ol>	
<p><b>Relocation:</b></p> <ol style="list-style-type: none"> <li>1) Change the nest box position if there has been no bluebird nesting attempt in a season OR</li> <li>2) Change by the end of the following April (75-90% of nest boxes have been occupied by bluebirds by then); if no nesting has occurred by the end of April your 2nd nesting season, it is a sign that your site is unappealing to bluebirds. But moving them to better nest sites still gives you a 50:50 chance of occupancy for the season.</li> </ol>	
<p><b>Box Style/Dimensions:</b></p> <ol style="list-style-type: none"> <li>1) In 'the wild', bluebirds prefer to occupy old woodpecker holes that are not usually very large</li> <li>2) Shallow, narrow boxes work best:             <ol style="list-style-type: none"> <li>a) 4-5" below the bottom of the hole as maximum depth</li> <li>b) 4 x 4", 4 x 5" nesting platform (inside dimensions)</li> </ol> </li> <li>3) No vents or keep vents closed until June 1 to prevent windchill from killing eggs and/or chicks</li> <li>4) Oval hole small enough to keep out starlings &amp; cowbirds</li> <li>5) Don't use predator guards on box fronts (too thick for bluebirds) or perches on boxes (used by predator birds such as sparrows &amp; kestrels). Instead, use a predator guard on your mounting post or make the mounting post your predator guard (3/4" electrical conduit preferred).</li> </ol>	
<p><b>Spacing:</b></p> <ol style="list-style-type: none"> <li>1) Space no closer than 100-200 yards (1-3 acre territories); encourages Tree Swallow occupation if boxes are placed closer than this</li> <li>2) Pairing reduces bluebird and increases swallow production/box</li> </ol>	
<p><b>Nest, Egg &amp; Chick Removal for bluebirds, chickadees, Tree Swallows (1,2,3) and House Wrens (4): Procedures approved by USFWS in Dec., 2006</b></p> <ol style="list-style-type: none"> <li>1) Partial or complete nests w/o eggs: 1st week; 2nd, 3rd, 4th weeks, no change, then remove; restart week count if more building occurs; if wet, remove, replace with dry, coarse grass or pine needles (white pine preferred)</li> <li>2) Eggs, full clutch in week 1; if do not hatch in 2nd, 3rd or 4th week, place back of fingers on eggs; if cold to touch, remove nest and eggs</li> <li>3) Chicks starving/lethargic: foster into nests with chicks of similar age, + or - 2 days [place with slightly younger, if possible]: 85% reared by adoptive parents in a 4-year study by the Aldo Leopold Audubon Society in central WI</li> <li>4) House Wrens only: The first week leave partial or complete nests in tact. If still no egg nest cup the 2nd week destroy dummy nest. Repeat if necessary. If egg cup or eggs are found in the 2nd week allow natural cycle to continue.</li> </ol>	
<p><b>Predator Guard on Mounting Pole/Post:</b></p> <ol style="list-style-type: none"> <li>1) Do not put boxes on wooden fence or electrical posts. The cheapest and most convenient mounting system uses 3/4" electrical conduit. Cut 10' conduit to 6'-8" lengths. Flatten 4" at end and bury 18" of conduit. To the remaining 5' conduit attach two 3/4" clamps and screw to box. Two 3/4" pieces can be joined with a coupler to make a 6'-8" post.</li> <li>2) House Sparrow predation: No nest box has proven to be sparrow proof (PVC/K-boxes work for some monitors)</li> </ol>	
<p><b>Direction of Opening:</b></p> <ol style="list-style-type: none"> <li>1) Keep away from prevailing westerly winds (cools boxes)</li> <li>2) Use the same direction for all boxes</li> <li>3) Cornell University has determined that directing the opening of a nest box to the <b>northeast, east or southeast</b> improves the fledging rate of Eastern Bluebirds in northern latitudes. Apparently, boxes pointed in that direction, heat up more quickly in the mornings in cold weather but do not collect as much heat from a southern exposure in summer.</li> </ol>	 <p><b>Bluebird Restoration Association of Wisconsin</b></p> <p><a href="http://www.braw.org">www.braw.org</a></p>

these cases, the adults adopted and raised these foreign chicks successfully. Had smell or disturbance been a problem, they would have rejected these fostered chicks. By the way, of those that died, most were exceptionally weak when put into the adoptive nests, and didn't have much of a chance for survival anyway.

Still not convinced? I will give you two more examples:

1) In two instances (wrens nearby & gas pipeline being put in), nest boxes with eggs had to be moved up to 200' from the original site. Instead of abandoning the eggs, both hens followed the boxes, incubated & hatched all eggs successfully and also successfully fledged all young.

2) One day I moved a box with five, 10 day old chicks (unknown to me), tossed it in the back of my trailer and transported it 15 miles to a site where I wanted to put up the box. To my dismay, I discovered there were chicks in the box and rushed back to the original site and put in post, guard and box under the watchful eyes of both bluebird parents. The box was away from the original nest site for 3 hours. In spite of this maximum disturbance, the parents continued feeding & raising the young and fledged all chicks.

Therefore, we "sell nesting birds short." We fail to remember that in the case of cavity nesting birds, they carefully inspect the box and surrounding habitat for its reproductive potential. When the hen eventually picks the

box, she has already decided (bonded to) that this is an ideal site for her to lay eggs and raise young. When she lays eggs, she has even more reproductive potential for her future (additional bonding) and when the chicks hatch, hell has to freeze over to get her and the rooster to abandon those young (maximal bonding).

So give the bluebird hen & rooster credit. Touching and modest disturbance of eggs, nest & young, will not cause them to abandon the nest, eggs, or young. Quite the opposite, they need your tender love & care to maximize their reproductive potential. By all means, do monitor your cavity nesting songbirds but with careful moderation.

**2) When you place a nest box, you are placing it in a permanent position, never to move it again.**

Nothing could be further from the truth. No nest box on any bluebird trail should be considered permanent unless it is attracting bluebirds! To do otherwise is to focus on your ego that is saying: "this place will be absolutely ideal for bluebirds". Well, I am sorry, but if bluebirds don't build in your house, they are saying, "sorry, monitor, I don't like where you placed the box—I can't raise young in these conditions". Don't you owe it to them to put it in a place where they can nest successfully?

I support the contention that "every nest box put up for bluebirds should afford a maximum opportunity to attract them". If you agree, then I recommend these principles of placement/moving boxes: "Any time you place a box in a new location, let it go a season and then until the end of

April in the following season. Our experience with Audubon nest boxes is that 69-90% of all boxes that will be used during the season, will be used by the end of April."

By moving any boxes that have had no bluebird nests in them by the end of April the 2nd season the boxes are in place, you have essentially given them two seasons to attract bluebirds, but can then place them in a new position that still has a 50:50 chance to attract a pair for the remainder of the 2nd season.

**3) Noise will prevent successful nesting in bluebirds.**

To me, it was surprising to find that bluebirds tolerate high levels of noise. The first insight I got about this fact was placement of a nest box in a park along a heavily traveled street on the west edge of Plover, WI. This box has been in place for six years and has successfully produced broods all five years and successful double broods in the past four of these years.

Armed with this experience, I selected a "very noisy railroad track site" along Hwy. 54 between Plover and Wisconsin Rapids. This site has thousands of automobiles passing along it (100-200' from the boxes) each day and up to 11, 100-box car freight trains, passing within 50-100' of the boxes each day. In an experiment in 2005, I placed four boxes along the tracks and three of the boxes produced bluebirds. In 2006 I expanded the trail to 36 boxes and 30 of them produced bluebirds. In 2007, 26 of 30 boxes and in '08 31 of 40 produced bluebirds. Noise was not a significant factor in limiting the production of



**Female Bluebird**



**Male Bluebird**



**Immature fledgling**

Pat Ready photos

bluebirds in this extreme situation.

What was most important was the habitat I selected. It consisted of a highway with a swath of vegetation of about 50' kept cut low (made it ideal for ease of insect observation), 20-30' high electrical wires overhead for perch hunting, short trees in front of the boxes for adults to perch on prior to entering the box with food and for young to fly to when they fledged, and railroad tracks with short grass hunting sites on both sides of the track. In spite of the noise levels, an excellent and productive habitat for bluebirds.

#### **4) One should not put boxes next to roadways for fear of bluebird adults/young being killed by passing cars.**

The majority of boxes on the Audubon Trail are along roadways. I know of no adult or fledgling that has ever been killed by an automobile (we have produced 13,837 young in 7 years of study). On the contrary, moderately traveled roads provide a great opportunity to raise successful broods and are safe for monitoring. Heavily traveled roads (see #3) can be outstanding for raising bluebirds but hazardous to stop along.

#### **5) One has to monitor nest boxes only once every two weeks or a month.**

This myth is being perpetuated by those who either don't have a commitment to monitoring songbirds or is over-committed, and lacks the time to do so. When one "takes on" the responsibility of nest box monitoring, it should mean a several hour commitment at least once/week. Anything less and the necessary commitment is lacking and monitoring should not be undertaken by a person under those circumstances.

When one assumes the responsibility for monitoring a nest box, you assume the responsibility to do what you can, to see that the natural cycle of the songbird is completed without interference from humans or other predators. Monitoring once per week assures: 1) accurate collection of data 2) nests and/or eggs will be removed from inactive boxes 3) removal of wet nests or wet nests with eggs or chicks can be replaced with dry nests

4) dying chicks can be removed and fostered into nests with healthy young 5) finding and controlling acute problems such as black fly infestations 6) fixing nest boxes, posts or guards that might have been damaged and that are threatening the safety of the songbirds in question and 7) locating and/or reporting any vandalism to your nest boxes.

### **Natural History Information for Cavity Nesting Songbirds.**

Natural history data has been collected each year (2002-08) of the Audubon Study. Table 3 is representative of the data collected during that time. Actual dates vary somewhat, but the over-all principles are the same. Swallows, wrens and sparrows (usually in that order but depending on the habitat) are the main competitors for nest boxes occupied by bluebirds throughout Wisconsin (individual trails may vary from these state-wide trends). Chickadees are a distant 4th as a competitor but do compete for boxes on some occasions.

In late March & early April, only chickadees and sparrows compete with bluebirds for nest boxes, as all start nesting about the same time (sparrows nest before bluebirds, bluebirds nest before chickadees). If one places nest boxes 100+ feet in the open, away from wooded edges (especially pine plantations), occupancy by chickadees is normally not a problem. Likewise, if you place your nest boxes some distance away from cattle and other livestock (200+ yards) or do not place your boxes in suburban neighborhoods where millet and corn are fed in the spring & summer, occupancy by sparrows is minimal.

Bluebirds have a "wing up" on swallows in that they will start building nests 3-4 weeks before they do. As our winters have shortened due to global warming, the swallow is narrowing that gap because they are migrating back from the Gulf Coast earlier. But for now, the bluebird faces less competition from the swallow for the first nesting than the 2nd nesting.

Even less is the competition from House Wrens. First of all, if one places a nest box 100'+ away from short & dense, brushy vegetation,

wrens usually do not build in those boxes and if they do so, build dummy nests. Secondly, wrens migrate back to WI even later than swallows. Since they do not even start nesting until mid-May, nearly 100% of nest-seeking bluebirds have selected boxes by then. Therefore, wrens are almost never a competitor in the 1st nesting cycle for bluebirds, but can become a major competitor in the 2nd and/or 3rd nesting cycles.

### **What kind of nest box should I use for a bluebird trail?**

In their natural environment, bluebirds largely occupy abandoned woodpecker holes. Therefore, boxes that simulate these holes work best. Shallow nest boxes with floors that are only 4-5" below the bottom of the oval hole and with an interior platform of 4" x 4" or 4" x 5", fledge the most bluebirds. For the BRAW data reported in 2006, the only boxes that fledged more than the statewide average of 3.5 bluebirds/box were, K-boxes, NABS/NABS-Style boxes & Peterson boxes. Moreover, these three boxes had among the lowest swallow occupancy of all the major boxes used. You can't go wrong by placing these three boxes on your routes if you want to increase production.

Those using nest boxes which attract fewer birds than the state average, should first be sure boxes are placed according to the principles in this guide and then consider replacing them with a higher producing nest box, if still producing fewer bluebirds than the state average.

It should further be noted that each of these box types has an "over-sized" opening (K-Box), or oval in both the NABS-Style and Peterson boxes. Oval holes have been shown to produce more bluebirds than smaller, round holes ([www.braw.org](http://www.braw.org) / Table of Contents: Bluebird Boxes: Round or Oval Entrance Holes by Close). Although difficult to prove, some investigators think that an oval hole allows adults to "tip-feed" their young without having to completely enter the hole as is the case with a circular opening. Theoretically, this behavior enables the adult to make more foraging trips/day than by



using a round hole.

It should be pointed out that 60.5% of all nest boxes being reported to BRAW in 2008 were of the three leading types listed. As others see the importance of providing a better style of box for increasing bluebird production, we should see the average number of bluebirds fledged/box increase steadily.

Meanwhile, it is possible to modify your boxes and still increase production, even though you do not replace them with the more productive boxes discussed. When we first built our Peterson boxes for the Audubon Trail, we used a poor model type and the nesting platform was 8" below the bottom of the oval entrance hole. This construction flaw forced bluebirds to build a nest that was nearly double the normal volume.

The second year, we inserted a platform into the box that was only 5" below the level of the oval opening. As Table 3 shows, we increased the bluebird fledgling rate by 60% from 2002 to 2003 with only this major modification of our trail (few boxes were moved). So, for those with deeper boxes, such as Hill Lake, Bauldry & Herman Olsen models, you can improve their productivity by simply inserting a new nest platform to made them shallower. Better still, however, shift to the "Big 3", more productive boxes.

## Monitoring Instructions.

### 1) Terminology

**Clutch:** Total eggs in nest

**Brood:** Group of young birds in the nest

**Broody:** Word to explain why a female does not want to leave the clutch when the box is opened

**Double Brood Box:** Boxes that have fledged two broods

**Triple Brood Box:** Boxes that have fledged three broods

**Fledged or Fledgeout:** The process of young permanently leaving the nest

**Fledglings:** Young that have flown from the nest permanently

**Juveniles:** Young that are living outside the nest; first stage of adulthood

**Juvenile Assisted Feeding:** Juveniles from the first brood who are assisting in feeding the 2nd or 3rd broods or

the juveniles from the 2nd brood who are assisting feeding in the 3rd brood.

**Nest Box Year:** A nest box that has been monitored for one season  
**Nestling** (= Hatchling, chick or young): Individual birds in the nest

### 2) Forms to use.

I prefer to use individual sheets for each nest box (Form 22). I think that this form allows you to record data in much more detail than if you use the "Monitor's Short Form" (20S). Whichever you chose to use, however, you should summarize the data on a Form 21 and send it to me by Sept. 1 (after October 10, your data will not be used for the Annual Report by Dunn & Hall in the Winter Issue of the Wisconsin Bluebird). When you use a Form 22, you are expected to determine the age of the young in the nest box to assure that you take caution as they age, in order to keep them from jumping out of the nest box (see photographic chick aging sequence of Dr. Jack Bartholomai on back cover). If you monitor the nest boxes once every 6-8 days (1 week average), it is usually pretty easy to determine the age of the young accurate to within a day.

The Form 21 was dramatically altered starting in the 2007 season. We eliminated spacing and nest box type in order to make the form more "user friendly". Also, we asked monitors to record data for not only bluebirds and Tree Swallows, but for both wrens and chickadees as they are important songbirds as well. All forms are available at [www.braw.org](http://www.braw.org).

### 3) Approaching & opening the nest box.

Monitor boxes once/week. Experience has shown that production of bluebirds improves if you visit one or more times/week. For example, if there is an extreme weather event and a nest gets wet, the eggs/birds can survive for only a few days. If you monitor the boxes only once every two weeks, you assure that the eggs/young will die under these circumstances. By visiting every week, you could build a dry nest and save the eggs/young (see below). Also, weekly monitoring helps you determine if the nest is active or not (see bold

font below). Destroying inactive nests increases productivity.

It is essential, whenever possible, to get the hen to leave the nest prior to opening the nest box. Several times on the Audubon trail, hens have been injured as they attempted to leave the box when it was opened but could not use the exit hole. On at least one occasion, a monitor was so startled that he/she slammed the door shut, thinking that the young were escaping and crushed and killed the hen in the door of the box. Such accidents are rare but can be eliminated by using the approach given below.

As you approach the nest box, make a loud pishing or clapping noise from 10-20' away. Pishing is commonly used by birdwatchers and involves making a shhhhhh sound with an explosive "p" sound preceding it (one continuous sound). If the hen does not flush from the nest, go to the back of the box and make loud tapping noises on it.

If the hen still doesn't flush, step to the side of the box, away from the opening and open the box. The hen should flush from the nest. If she still does not flush, return to the back of the box and make both a pishing and tapping sound. If she is still so "broody" that she stays on the eggs (less than 5% of the time if the above protocol is followed), simply reach in and firmly pick her up from the nest and toss her in the air. She will chatter at you, but injury is not a problem with this technique (remember that smell is not a problem and this capture technique is used by bird banders on a regular basis). I have used this technique dozens of times without harm to the hen. This technique can also be used with other songbirds, but a hen swallow will grasp nesting material, so care should be taken when removing her, so you don't remove her eggs.

By using these techniques, you should be able to get an accurate count of eggs and young, important data for BRAW.

### 4) Counting eggs & nestlings.

After you have flushed the hen from the nest, you are then ready to count the eggs and/or nestlings.

### Counting eggs:

A complete clutch (= total) is 4-5 light blue eggs. In unusual cases, probably associated with exceptionally good habitat & feeding conditions, 6 eggs are laid. In all of the nests of eggs laid in the past 7 years of the Audubon trail, only four have had 7 eggs and one had 8 eggs. So such clutches are possible but ultra-rare. More commonly, but representing 2-3% of all eggs laid on the Audubon Trail, are "white eggs". None of our white egg nests ever have any blue eggs in them, so this condition seems to be a fixed genetic trait that does not vary over the lifetime of the individual, apparently a type of "egg albinism" (Gowaty and Plissner 1998).

When you look into the "hen-less" nest, pull back the cup edge and you will be able to see the eggs.

If it is a Tree Swallow nest, you must part the feathers to find the eggs. The eggs of chickadees are covered when the hen leaves the nest during egg laying, so carefully pull back the hair covering them to get a count. In some cases, it is best to "touch-count" the eggs. This technique allows you to count the eggs with minimal disturbance. Rarely, you will find a larger, brown-mottled egg in the nest that is likely to be that of a Brown-headed Cowbird. This bird is protected and the egg should be left in the nest to complete its natural cycle.

To help prevent this parasitism, reduce the size of your box opening.

Incubation takes 13-14 days in bluebirds (Erhlich et al. 1988). However, data collected on the Audubon trail indicates that in cold weather, eggs may sit in the nest for up to 13 days before incubation begins, a very good reason to give the nest at least four weeks with a full clutch, before destroying the nest.

### Counting nestlings:

Healthy nestlings that are hungry will naturally "gape" when you open the nest box. If they are sleepy or recently fed, they usually can be enticed to gape by making a light pishing, kissing or whistling sound. If neither of these efforts allow you to get an accurate count of the nestlings, simply pick up one or two of them and spread out the others. I have

used this technique hundreds of times without any harm to the young. And, remember, smell is not a problem for cavity nesting songbirds. Rearing chicks takes 15-21 days, depending on the time of year (spring is longer, summer shorter; Berger et al. 2001).

### 5) After the young have fledged, what do I do with the old nest?

I ask monitors on the Audubon trail to remove the nests from the boxes after the young have fledged.

They are further asked to scrape off all feces on the sides of the boxes, but do not have to wash out the inside of the box. For those that are compelled to more thoroughly clean out the box, however, use only water and a towel (no soap; windex spray bottles work well).

I recommend removing the old nest from the area by placing it in a plastic sack and disposing of it in the trash at home. While insects such as blowflies are rarely a problem for songbirds in our experience, there is only one reason to leave the nest in place, that of leaving the jewel wasp, a parasite on blowflies, in place to parasitize blowflies in the next nest (Berger et al. 2001). Since it has been our experience that blowflies are not injurious to bluebird nestlings and that old nests block nesting attempts by other bluebirds, we still recommend removing the old nests except in the situation that follows: The longer one has a trail in place, the more common are second (and third) nestings. This means that new nests will sometimes be started prior to removing the old nest. In that case, the new nest can be built so high that it makes the bluebirds more vulnerable to predation because they are so close to the opening. If the nest is sturdy enough, it is possible to lift it off of the old nest and remove the old nest from under it. In other instances, it is so flimsy that it is best to leave the old nest underneath the new one. It is not worth the risk of disturbing nest building and the abandonment of the box by the hen.

### 6) What should I do if nests remain incomplete, empty or with unhatched eggs?

**All songbirds are protected by the**

**Migratory Bird Treaty Act of 1918. The Act states: "unless and except as permitted by regulations...it shall be unlawful at any time, by any means or in any manner to pursue, hunt, take, capture, kill...possess, offer for sale, sell, purchase, ship, export, import..., transport or cause to be transported...any migratory bird, any part, nest, or eggs of any such bird...included in the terms of conventions between the United States and (Canada)...the United Mexican States...and the...Government of Japan". BRAW absolutely supports this law. It is therefore illegal to destroy any nest, eggs or young of any songbird except in the following situations approved by Ms. Andrea Kirk, Permits Chief, Migratory Birds, USFWS Region 3, Ft. Snelling, MN 55111 on Dec. 27, 2006. Ms. Kirk has determined that nests and/or eggs of any songbird are inactive in the following situations and can therefore be destroyed:**

- 1) Partial Nests of any songbird that is monitored regularly:  
Week 1  
If there is no more additional nest building in weeks 2,3 or 4, the nest can be removed in the 4th week. Timing restarts when there is any additional nest building**
- 2) Complete Nests of any songbird that is monitored regularly:  
Week 1  
If no eggs are laid in the nest in weeks 2,3 & 4, nest can be removed in the 4th week.**
- 3) Complete clutch of eggs of any songbird that is monitored regularly:  
Week 1  
If none hatch in weeks 2,3 or 4, touch eggs with back of fingers. If cold to touch, nests & eggs can be removed in the 4th week.**
- 4) House Wrens only: Leave partial nest or incomplete nests in tact the first week you find it; if still no egg cup the 2nd week, destroy the dummy nest; repeat if necessary; if egg cup or eggs are found in subsequent weeks, allow natural cycle to continue.**

Five years of data collection from Audubon led to this ruling by Ms.

Kirk of the USFWS. It is our experience that when empty, partial or complete nests, or nests with unhatched eggs are left in the box, it "blocks" nesting attempts from individual hens that started the nest or from new hens. Although we do not know which "type of bluebird" is being blocked, our data indicate that removal of the nests using the procedure listed above, leads to a new nest being built and/or clutch of eggs laid by a bluebird, within one or two weeks in most boxes when this procedure is followed in the months of April through June. Leaving the nests or eggs in place delays further nest attempts by up to 6 weeks.

**On December 2, 2006, the BRAW Board voted 12 to 0 to establish the following policy:**

***"No bluebird monitor's data will be accepted for seasonal reporting if they are known to destroy active songbird nests".***

**Monitors are expected to follow the criteria for inactive nests approved by the USFWS on Dec. 27, 2006. If they do not and indicate that on their BRAW Form 21's or in personal conversation with BRAW Board members, their data will not be accepted for consideration in BRAW reports and their names will be submitted as violators of federal law to the USFWS.**

## **7) Problems encountered while monitoring boxes**

### **a) Nest boxes occupied by other bird species.**

Swallows, wrens & chickadees are "good guys", i.e., songbirds. They should be treated with respect as described above. The best technique to keep song birds other than bluebirds out of your boxes is to put them in habitat preferred by bluebirds, not other species.

Swallows prefer habitat with water over the drier, upland habitat preferred by bluebirds. Keeping boxes away from water (including marshland) will increase the chances of attracting bluebirds to them.

Wrens love short & dense, brushy vegetation with shading. Keep boxes 100' away from such vegetation and

usually only a dummy nest is built. It is best to move the box another 50-100' away from the dense vegetation if nesting is attempted.

Chickadees are the least likely to occupy a bluebird house. They prefer edges of conifer woods and shaded nesting habitat. Keeping boxes 100+ feet away from such habitats will usually eliminate their nest attempts. Sometimes they will occupy a box in the open, far away from woods. But it is rare that these nests are successful. There really is nothing you can do to prevent these occupations. But three weeks after you experience a completed clutch without hatching, touch it to see if the eggs are being incubated (chickadees cover their eggs when they leave the nest, so carefully remove the hair covering them to "feel" the eggs). If they are cold to the touch, you can legally remove the eggs and nest. Our experience is that chickadees are the least successful of all the songbirds attempting to occupy our bluebird houses and they are most likely to be ousted by bluebirds.

**"House Sparrows are not native song birds and can legally be destroyed in any life stage: nest, eggs, young, adults."** For six years, Audubon monitors have struggled with the drop in reproductive potential of bluebirds, that sparrows cause. We continue to experiment, but so far, we have concluded that no nest box reduces sparrow occupancy while encouraging bluebird occupancy. Davis & Roca (1995) and Jerry Schoen and Terry Glanzman, BRAW Board members claim that slot boxes help them control sparrows. It should be noted that the Troyer Slot box is the worst bluebird producer of all the major boxes, however. Gary Gaard has recently claimed good success with a pvc nest box for sparrow control. Audubon research agrees that these boxes prevent sparrow occupancy. Unfortunately, neither bluebirds nor tree swallows prefer to nest in them either.

What works best for most monitors, however, is to keep the boxes at least 200 yards away from livestock farms and out of suburban subdivisions where residents are feeding cracked

corn and millet, as they are ideal foods for sparrows. That being said, we still have 7% of our boxes infested with sparrows.

One technique that has been used by Audubon monitors to permanently discourage sparrows is to let them lay their eggs and start incubating them (warm to the touch). After incubation begins, remove both nest and eggs. We have never had a sparrow lay more than two clutches of eggs in a box before giving up and allowing a songbird to take over the box.

Sparrow "scarecrows or spooks" have proven ineffective in scaring off sparrows as they quickly adjust to them and return to the boxes.

Finally, some people use a variety of sparrow traps to capture and destroy the adults. That is a permanent solution only if the male is captured as he will simply attract a new hen. Sparrow capture is so labor intensive that it is rarely used in trails of more than 25 boxes. If you try to trap sparrows, set out traps as you monitor your trail. When you finish monitoring, return to the boxes to remove any trapped sparrows or song birds. Dispose of adult sparrows and release the songbirds. If you leave the trap unchecked overnight, songbirds can die during that time.

### **b) Wet nests.**

Rarely do nests get wet in boxes. If they do, the most common reason is a "leaky box". The first consideration, therefore, is to repair the box by replacing boards, tightening them or caulking leaks. Sometimes, under extraordinary conditions, winds will blow so strongly, that an otherwise "water-tight" box will "take on water" and produce a wet nest.

Songbird hens, including the bluebird, incubate their eggs at about 97F. A wet nest quickly drops the egg temperature below this level, causing arrested development. Wet nests also cause abandonment of nests prior to egg laying. If there are young in the nest, especially less than a week old, they will quickly die of hypothermia from a wet nest, especially in cold weather.

The bottom line is, replace all wet nests with dry material. It is best to begin the season with a small sack

**continued on page 14**



# Nest Guide to Cavity Nesters

by Patrick Ready/BRAW

## Eastern Bluebird

Fine or coarse grasses, pine needles, lined with fine grasses.



## Tree Swallow

Similar to bluebirds, coarser grasses & straw, lined with feathers when eggs are laid.



## Black-capped Chickadee

Moss, fine grass, lined with animal hair.





## House Wren

Sticks and twigs jammed in tight. Lined with a small amount of fine grass and hair. Often builds dummy nest with a few sticks but without lined cup.



## House Sparrow

grass, straw, feathers, paper, plastic, etc. and they usually swirl the grass upward to fill the box, then tunnel down in. Sometimes when a nest is first started it may be hard to tell what species is nesting. Wait a day or two to see how the nest develops. Feathers and wrappers early on with some grass pieces are definite signs of House Sparrows.



Above: Peterson box filled with straw, grass, and garbage indicate a House Sparrow nest.

Middle: Eggs-white or grey with brown specs

Left: Beginning nest. Similar to bluebird and tree swallow but note chicken feathers and debris = signs of a House Sparrow nest.

# Species Identification of cavity nesters

Male & female Eastern Bluebird



Female & male Tree Swallow.



Black-capped Chickadee, sexes similar.

House Wren, sexes similar.



of dried vegetation, good enough for making up to 6 nests. We carry a bag of white pine needles.

All too often, when you experience finding a wet nest, all other vegetation around the box is wet. "Plan ahead" is a good policy when it comes to wet nests. Once the hen completes a nest, she will tolerate any kind of cup-shaped vegetation that might be available to make a "humanly-constructed" nest.

Preferred materials, however, include white-pine needles and any dead but soft, short-leaved grasses.

All the monitor has to do is form a cup-shaped nest approximating the dimensions of the nest in the box. Remove the eggs or chicks from the wet nest and place them in the dry nest. Put the dry nest with eggs or chicks, back into the box and pat it down a bit to approximate the size & shape of the previous nest. Do not worry about this part of the process, however, as the hen will quickly arrange the new nest to her liking. Audubon monitors have done this procedure dozens of times and it is 100% successful if the nest can be replaced soon after it gets wet. It should be noted that it is common for hens to use damp grasses while building nests. These dry out quickly. Don't change wet nests unless they have eggs or chicks in them.

#### c) Starving chicks in the box.

In 2005-08, a total of 70 nestlings were found starving in the boxes on the Audubon Trail. 60 of them were saved by following the procedures given below:

The first step is to identify starving chicks. If there is a dead chick in the nest already, that is usually a good sign that other chicks in the nest are stressed as well. It is more likely, however, that you will discover starving chicks by finding them largely unresponsive to your typical pishing/kissing/whistling noises. In addition, if no adults are seen around the nest box, it is likely that one or both parents are dead or have abandoned the chicks. The chicks must be lively enough that they can still "gape". Otherwise, fostering them will not work.

If it is cold weather, wrap the young in tissue or toweling that will keep



Jack Bartholmai

them warm. If it is hot weather, heat will be their enemy, so keep them as cool as possible.

You should try to locate a nest with chicks in it that are somewhat younger than the age of the chicks that are starving. This strategy is important because the starving young are retarded in their physical development and after being adopted by the new parents will grow at about the same rate as the younger chicks.

Often, however, trails are so small that not many choices are available to use for adoptive nests. I have successfully fostered chicks into nests in which the occupant chicks were 6 days older than the adopted chick(s). This places a hardship on the parents, however, as they have to cope with juveniles outside the box and a chick(s) inside the box. But the technique will still work.

Another rule of thumb is to put no more chicks into the adoptive nest than will total 5 or 6 (6 only if absolutely necessary). Two healthy adult birds can raise 5 chicks in most cases, but coping with 6 is stressful and can lead to the loss of the adoptive chick.

#### d) Critters invading the box.

##### i. Blackflies.

Blackflies are the most dangerous insect for cavity nesting songbirds. They seem to be most common in the southern and western part of the state, particularly around slow moving rivers. Gary Gaard, BRAW member from Dane County, has done research that implies by removing vents from boxes, black fly infestation can be eliminated. Research done in western counties in the summer of 2008 show that dozens of chicks died from black

flies in spite of having vent free boxes. At this time there is no way known to prevent deaths of chicks in nest boxes during severe outbreaks of black flies. So if you are losing entire broods, healthy one week and a dead, amorphous mass the next, it could well be blackflies. Check around the wings and abdomens for small bite marks, the sure signs of black fly infestation. These deaths almost always occur in 2nd or 3rd broods during years of heavy rainfall.

##### ii. Blowflies.

In the 7 years of the Audubon study, 2993 nest boxes have been monitored, representing 2993 nest box years. During this time, no known deaths have occurred to nestlings because of blowflies. We think they are a non-issue, at least in central WI. During the months of June-August, we find their maggots in up to 50% of our nests.

Blowfly larvae are gray-brown and about 1/2" long and are usually not very active when you find them in the nests. It is true that blowflies are ectoparasites on nestlings, attaching to the abdomens for nourishment. Typically, these "feedings" occur at night and the larvae return to the safety of the nest during the day.

My advice is to ignore the blowfly larvae because they are harmless to the songbird young. But if you think they are a problem, you can get rid of them by removing the infested nest and replacing it with an artificial nest that you construct as per the instructions above.

##### iii. Ants.

Ants are rarely a problem in nest boxes in central WI, although they have been known to attack, kill, and devour newly hatched nestlings on occasion. They may even attack and kill the young birds by entering the eggs as soon as the shells are cracked in the hatching process. (Zeleny 1976).

Pyrethrin sprays are safest for spraying ants in nests but they are short acting. On the Audubon trail we use "Bonide Termite and Carpenter Ant Dust" (Bonide Products, Inc., Oriskany, NY). Lift the nest with a paint scraper and spread dust over a 2" x 2" surface of the nest platform. This is a contact poison so do not aspirate it into the area or chicks and



adults can breath it. Using these application techniques, we have noticed no harmful effects to nesting birds. Wear a rubber glove for application.

#### *iv. Mites*

In our 6 years of monitoring nest boxes, we have recorded no known fatalities from mites. In fact, it is rare that they occur in numbers large enough to be detectable by humans. But sometimes, they overrun a nest and must be dealt with when removing the old nest. It is best to use gloves as they are "creepy crawlers" of the worst kind. They do not harm humans (and apparently the birds in the box), but they are uncomfortable if they get on your skin. Just rub them off and try to "dust out" the box as best you can so the next brood will not start with a bad mite infestation. It is our experience that mites are more common in Tree Swallows than other songbirds.

#### *v. Wasps*

Rarely, wasps attach inside the nest box but more commonly they attach underneath it. It is always possible to get stung by them, so caution should be used when removing the nest. To prevent their further attachment to the same site, spread vasoline or bar soap over the place the nest stalk attached to the box. Peterson nest boxes are particularly prone to wasp infestation.

#### **e) Climatic Effects.**

In northern latitudes, cold has proven to be the most limiting factor during the reproductive season, much more so than heat (as reported by bluebird monitors across the state).

In 2006, for example, an intense low pressure system dominated the weather throughout Wisconsin during the week of May 11 & 12. For 48 hours on those two days, cold, wind-driven rain fell and caused hens to abandon eggs and/or chicks in order to survive themselves.

In the two days of May 11-12, a total of 286 eggs & chicks were lost on the Audubon trail. That 2-day number represented 26% of the total loss of 1098 eggs & chicks for the entire season and exceeded the total loss of eggs & chicks in the two hot months of July & August. This is an extreme example of the underlying principle that the majority of egg & chick loss occurs in

the colder months of April & May.

The most sophisticated temperature studies done by BRAW members are those by Marking, Craig & Koperski (2006, 2008) and other members of the Brice Prairie Conservation Association (BPCA). In two studies on temperatures in nest boxes, they made these important observations: 1) east facing nest boxes showed increased temperatures as they were hit by the morning sun (this temperature spike supposedly explains in part why bluebird production in northern latitudes increases when boxes are placed in ne, e or se-facing directions [Dhondt & Phillips]) 2) Non-vented boxes are warmer in spring and cooler in summer than vented boxes. Eliminating vented nest boxes during springtime has led to improved bluebird production by BPCA and 3) painting nest boxes dark colors increases heat stress in bluebird chicks in the months of July and August and should be avoided. Painting is not necessary, but if it must be done, light colors should be used.

#### **The Well-Equipped Monitor.**

The following suggestions are only guidelines and include materials for repairing nest boxes, something that you might have to confront. It all starts with a container of some kind. I use a small bucket, others use a knapsack, still others a fanny pack or fishing tackle box.

Below is a list of items that can be useful when you monitor nest boxes:

- 1) Form 22's (not Form 20S) & #3 or #4 pencil (corrections do need to be made on occasion)
- 2) Clipboard or notebook to hold data forms
- 3) Flat, paint scraper to remove old nests; plastic sack for old nests-Brush to clean out nest box
- 4) Pilers & screwdriver for a myriad of purposes
- 5) Hammer & caulking gun to repair nest boxes
- 6) Fence post driver and cordless drill for putting in posts/ attaching nest boxes

#### **So Why Else Should We Monitor Bluebird Boxes?**

At the start of this "Informational Packet", I indicated that a major reason for developing bluebird trails is to preserve bluebirds and other cavity

nesters. But bluebird trails are more than just for conservation of the creatures of creation. It is for us. It is vital for us to be associated with a conservation project.

Few persons in the world have the chance to experience the wonder and mystery of the reproductive development of a wild creature. But nest box monitors do. This is a sacred experience that should be shared with as many people as possible.

It is likely that in this modern age of technological marvels, fewer and fewer children have the chance to "experience nature". Take adults & especially children, with you on your monitoring trips. Explain to them the wonders that you see each time you go out on your trail.

Good luck finding, raising and fledging "the blues" and other cavity nesting songbirds.

#### **LITERATURE CITED**

- Berger, C., K. Kridler, and J. Griggs. 2001. *The Bluebird Monitor's Guide to Bluebirds and Small Cavity Nesters*. Harper Collins Publishers, Inc., New York, NY.
- braw.org/BRAW Articles
- Close, W. *Bluebird Houses: Round or oval entrance holes?*
- Marking, L.L., F. Craig & C.A. Koperski. 2006. Effects of shade, insulation and Heat reflective Materials on Temperatures of Bluebird Nest Boxes. *Wisconsin Bluebird*, Vol. 21, #4.
- Marking, L.L., F. Craig & C.A. Koperski. 2008. The Effects of shade and Ventilation Combinations to Alleviate Temperature Problems in Bluebird Houses. *Wisconsin Bluebird*, Vol. 23, #1.
- Davis, W.H. and P. Roca. 1995. *Bluebirds and Their Survival*. The University of Kentucky Press, Lexington.
- Dhondt, A.A. & T. Phillips. 2001. A Question of Preference: Does the orientation of a nest box affect the breeding success of cavity-nesting songbirds? *Birdscope from Cornell Laboratory of Ornithology*. Spring, Vol. 15, #2.
- Ehrlich, P.R., D.S. Dobkin, and D. Wheye. 1988. *The Birder's Handbook*. Simon & Schuster, Inc., New York, NY.
- Gill, F.B. 2007. *Ornithology, 3rd Edition*. W.H. Freeman, Co., New York, N. Y.
- Gowaty, P.A. and J.H. Plissner. 1998. *Eastern Bluebird (Sialia sialis)*. In *The Birds of North America*, No. 381 Poole and F. Gill, eds.). The Birds of North America, Inc., Philadelphia.

# Fence post mounting system

Brice Prairie Conservation Association uses the "T" post method to mount NABS Style nest boxes on their trails in the LaCrosse area.

## The "T" post method by Leif Marking



- Nest box lumber is 7/8" western cedar with rough side exterior
- 7 ft steel T-type fence post to accommodate the 1 1/2" PVC predator guard
- 5 ft section of 1-1/2" PVC cut partially for U-bolt-see photo (drain pipe or electrical conduit available in 10 ft sections)
- U-bolt that measures 5/16" x 2" x 3-1/4" available at Farm and Fleet

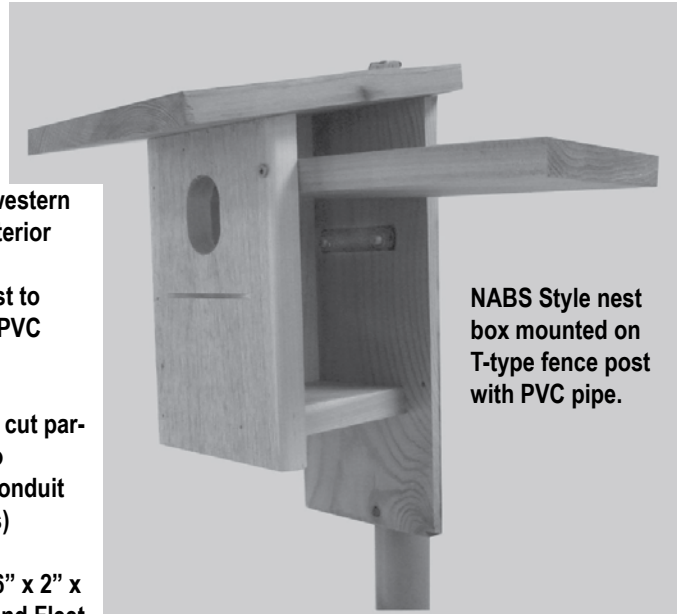

NABS Style nest box mounted on T-type fence post with PVC pipe.

These photos show how the single U-bolt through the slotted PVC fastens the predator guard and box to the steel T-type fence post. The common T-type fence post is cheaper, stabler, sturdier, and removable without mutilation.

## 3/4" Conduit Mounting System

By Bob Tamm

1. Using a standard 10 ft. section of 3/4" EMT conduit (available at Menard's, Home Depot, etc.), cut off about 2 - 2 1/2 ft. (hack saw) and discard.
2. Flatten tip of the 7 1/2 ft. or 8 ft. section with hammer or sledge. This makes it easier to pound pole into ground, and prevents it from turning.
3. Loosely attach 3/4" EMT conduit 2-hole straps to back of box using 3/4" deck screws. (Note: 3/4" deck screws are hard to find. I get mine at Menard's.)
4. Using post pounder, pound long conduit section into ground, allowing about 6 to 6 1/2 ft. above ground.
5. Slip box with straps onto conduit and adjust box for height. Then tighten screws.

Note: If you would like to use the entire 10 ft. section, try this: Measure two sections to 6'-8" and cut. You will have two left over 3'4" sections, which will make a third 6'-8" section if you use a coupler. If you drive these sections about 14 inches into the ground, you will still have enough conduit above ground to mount a box on the 5 ft. above ground conduit. You then have three mounts from two 10 ft. sections.



**Individual Nestbox Weekly Field Record  
Bluebird Restoration Association of Wisconsin, Inc.**

Name _____	Year _____	Box design name (See sketches on back of form for some of the most productive box designs)
Mailing address _____	Height of hole: _____ (distance to ground in nearest 1/2 foot)	
City _____	County _____	
State _____ Zip _____		
Phone (     ) _____		
Location of box _____ (including distance from reference points)		

**Box support** (circle one): 1. T metal post 2. U metal post 3. Conduit rebar 4. Other (list) \_\_\_\_\_

**Was a predator guard used on this box?** (circle one) 1. PVC tube 2. Rain gutter 3. stove pipe 4. Other (list) \_\_\_\_\_

**Habitat** (circle best description): 1. Grassland 2. Pasture 3. Orchard 4. Fence row 5. Cultivated field 6 Forest edge  
7. Suburban 8. Building site 9. Wetland Other \_\_\_\_\_

Date of visit	Check made by	Is nest present	Number of eggs	Est. date of hatch	Number of young	Number fledged	Bird species	Comments: (Condition of young, parasites, predation, banding, future box repair, encroachment of woody vegetation, observation, etc.)

\_\_\_\_\_ The U.S.F.W.S. guidelines for active nests were followed while monitoring the nests of all songbird species during my/our study.

**Please send in your data on a BRAW Form 21 by September 1 to: Kent D. Hall, Ph. D.,  
200 Pine Bluff Rd. Stevens Point, WI 54481**

**Box Number**

# ANNUAL BIRD NESTING SURVEY SUMMARY

The 2007 Annual Nesting Survey eliminated spacing and box type. The BRAW Board still considers spacing (100 yards+) and box type (see below) important, but many monitors told us it was difficult to interpret what data was wanted, so we changed the form and asked for 1st, 2nd & 3rd broods. Unfortunately, this request was also difficult to interpret. So, to assure accurate collection of data in 2008 and beyond, the BRAW Board has changed the form again. This time we are asking for nesting attempts instead of broods. Each bluebird nesting attempt with eggs is recorded sequentially, regardless of whether it/they fledged young. We ask that you provide complete data (including eggs and hatchlings). **Otherwise the report will not be included in the BRAW Annual Report.** BRAW monitors are expected to collect data from each of the songbirds below and to protect their nests.

Please return this completed form by September 1 to BRAW, Inc., c/o Dr. Kent Hall, 200 Pine Bluff Rd., Stevens Point, WI 54481.

Any reports received after Oct. 10 will not be included in the Annual Report.

Name \_\_\_\_\_

Address: \_\_\_\_\_

City \_\_\_\_\_ State \_\_\_\_\_ Zip \_\_\_\_\_

Telephone (\_\_\_\_\_) - \_\_\_\_\_

Email Address: \_\_\_\_\_

County where boxes are located? \_\_\_\_\_

Use a separate Survey Summary form for Each County.

Total Boxes Presented:  
(Sum of used & unused) \_\_\_\_\_

**IMPORTANT:** Number of boxes with no nests  
during the current season: \_\_\_\_\_

Number of boxes with at least one  
bluebird egg laid in them: \_\_\_\_\_

Number of boxes in with a House Sparrow Nest: \_\_\_\_\_

Species	Bluebird Nesting Attempts			Tree Swallow	House Wren	Black-capped Chickadee
	* First	Second	Third			
<b>All Nest Attempts:</b> Number of nests in which at least one egg was laid.						
<b>Egg Count:</b> Total number of eggs laid for all nests, including those that don't hatch.						
<b>Hatchlings:</b> Total number of eggs hatched for all nests.						
<b>Fledglings:</b> Number of young birds that fledged from all nests.						
<b>Successful Nest Attempts:</b> Number of nests in which at least one young bird fledged from a nest (Often is less than all nest attempts)						

\* First nesting attempt in all boxes in which at least one bluebird egg is laid (then second nesting attempt then third nesting attempt). Nest attempts without eggs are not to be entered.

**Note:** All five lines of data must be included in the Form 21 report in order for it to be included in the final Annual Report for BRAW.

Many box types are being used by Wisconsin bluebirders. But only the following box types had averages above the 3.5 bluebird fledglings per box for the 2006 season: K-Box, NABS-Style and Peterson.

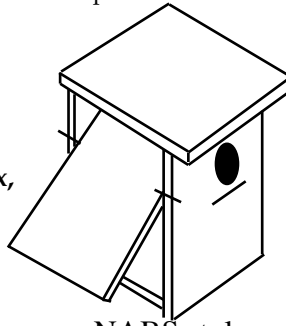

NABS style

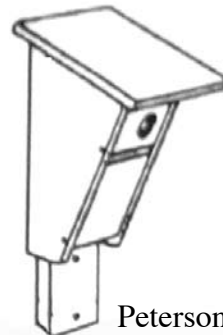

Peterson

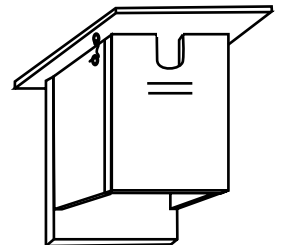

K-box

Type of mounting system used: \_\_\_\_\_ T-shaped fence post \_\_\_\_\_ U-shaped fence post \_\_\_\_\_ Conduit/Rebar

Do you use predator protection for your mounting system? \_\_\_\_\_ PVC \_\_\_\_\_ Aluminum \_\_\_\_\_ Other \_\_\_\_\_ None

\_\_\_\_\_ The U.S.F.W.S. guidelines for active nests were followed while monitoring the nests of all songbird species during my/our study.

# NABS style Bluebird Box

Cedar, 7/8" lumber preferred.

8" wide for top

6" wide for back, front, sides & bottom

All angle cuts are 10 degrees

Roof is 7-1/2" wide x 10-1/2" long

Sides 9-7/8" long x 5" wide

Floor is 5" x 3-3/4"

Back & front 5-1/2" wide

## Recommended Oval Hole Plan

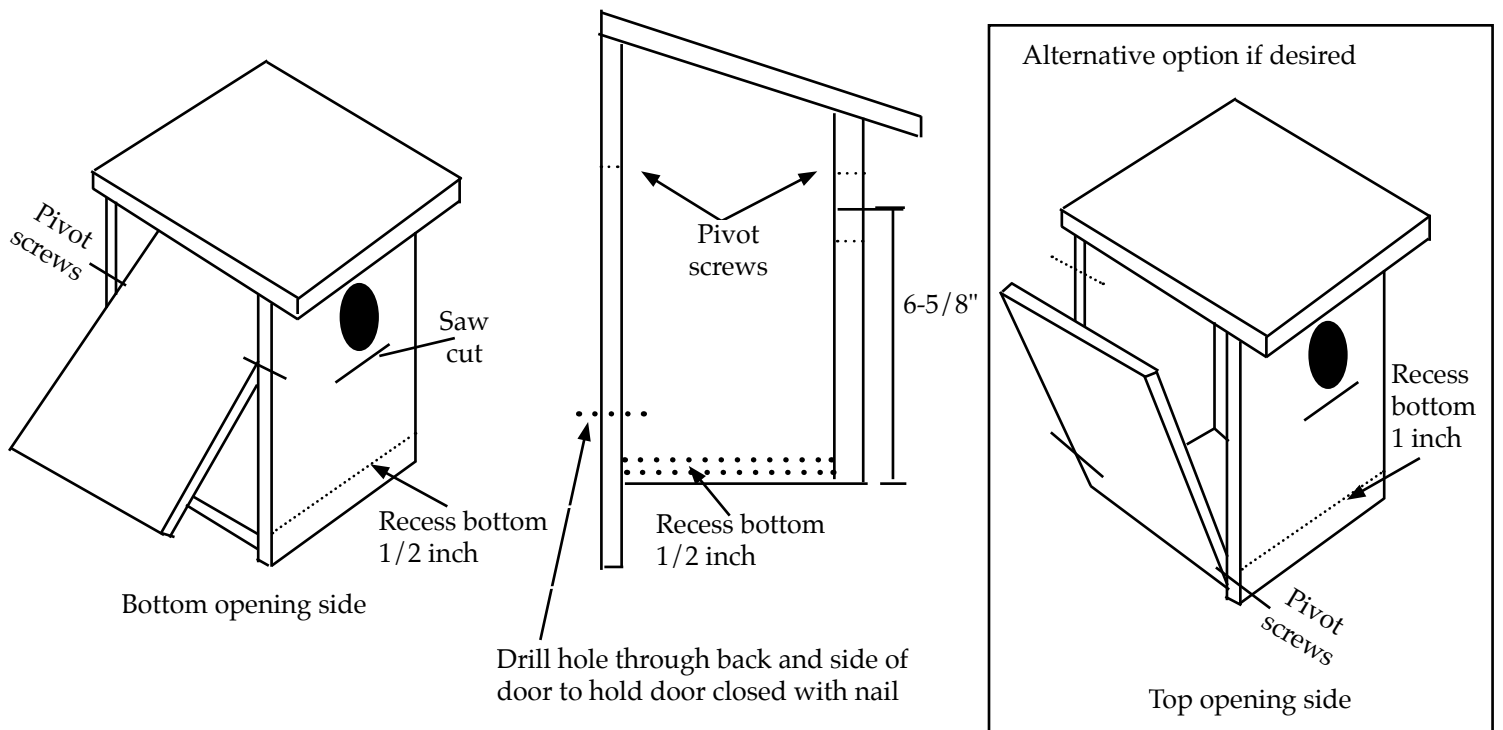
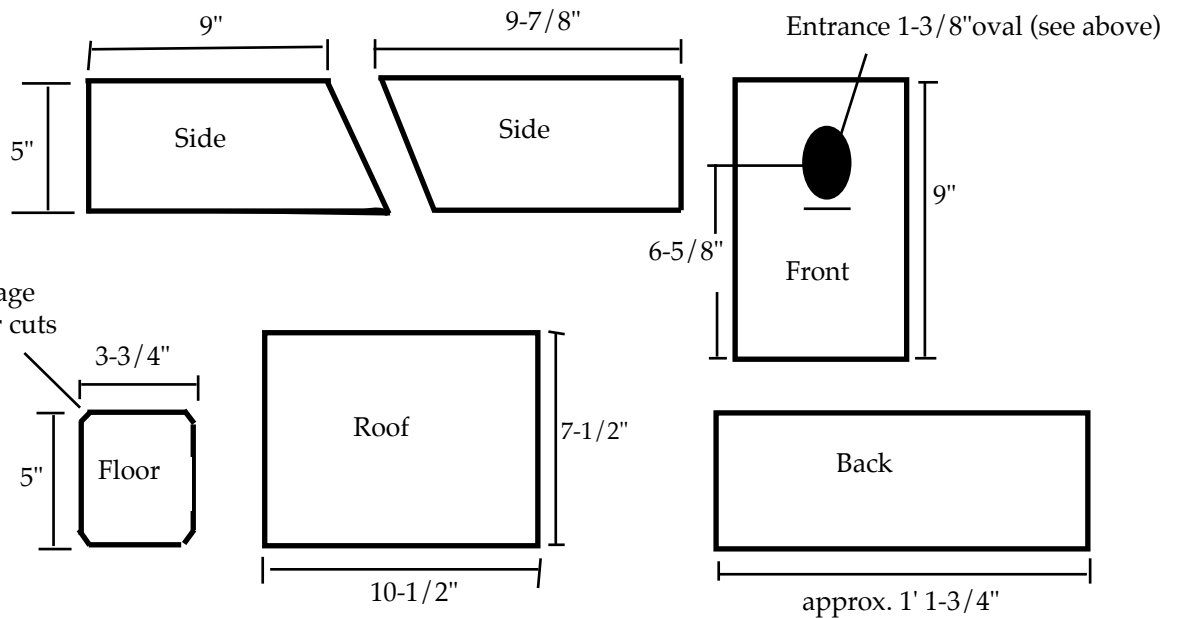
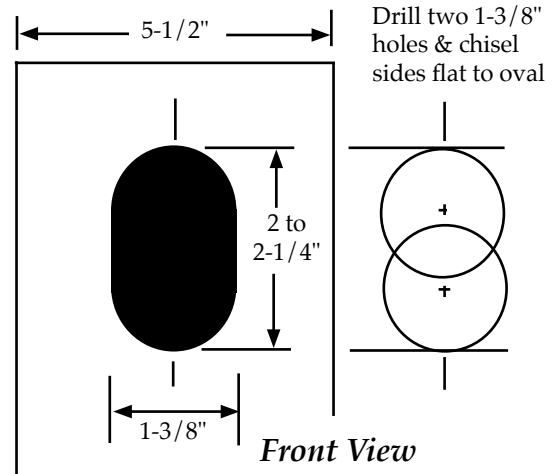

# Peterson Nest Box (Unvented)

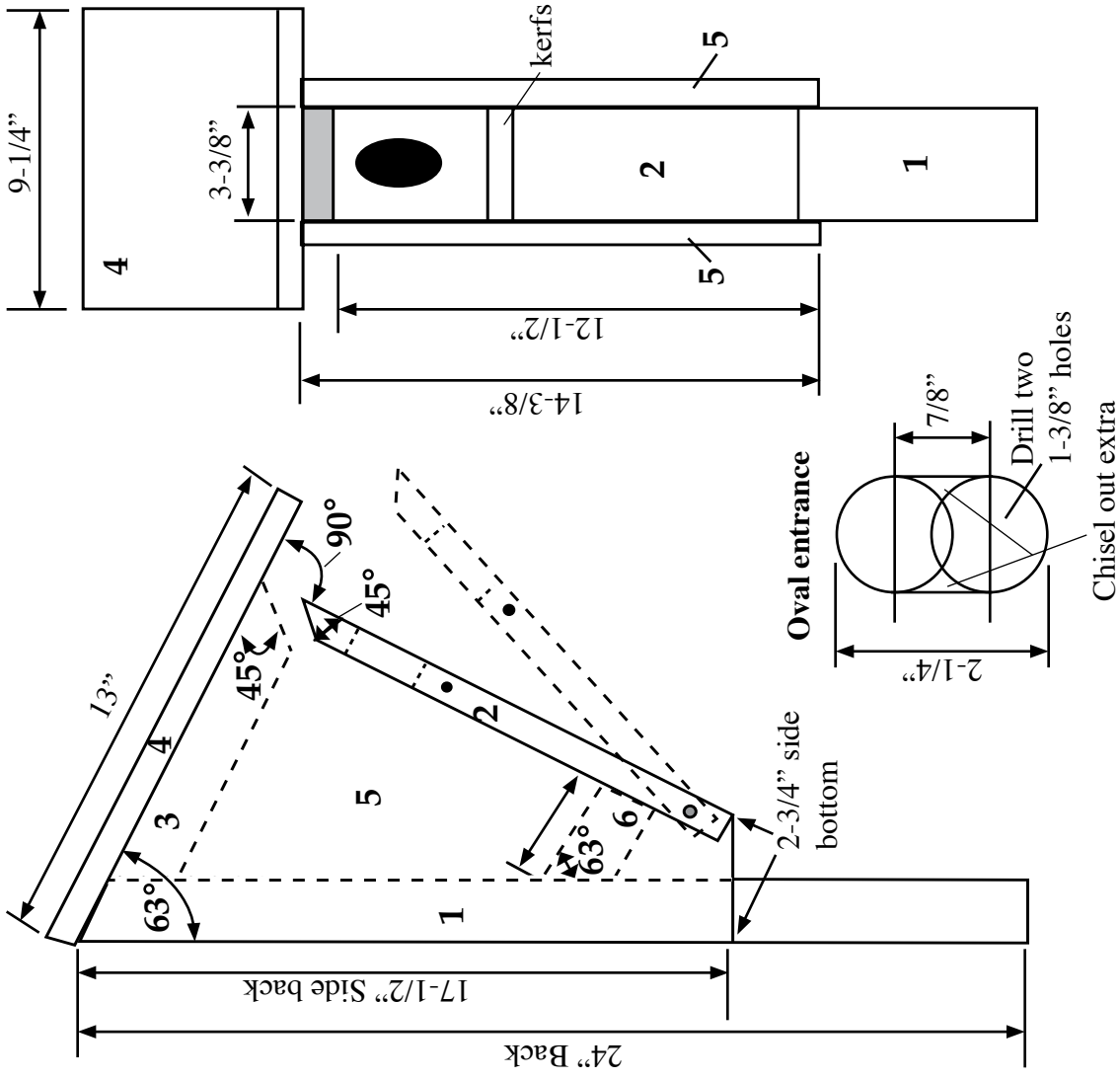

The Peterson Box is more difficult to build but is an attractive design and makes an excellent bluebird nest box. Read the plans carefully before deciding to build this box. Make sure your skills are up to the task. Because of the size and weight a "T" post mount is recommended.

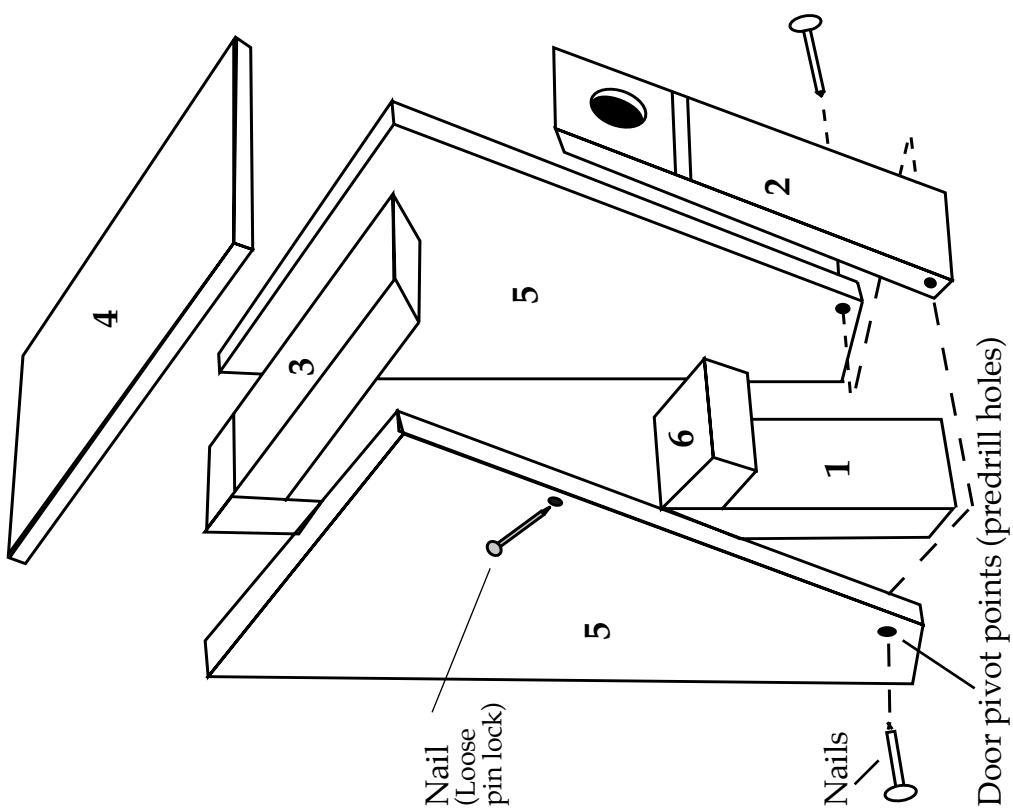

## Materials List

- 1. Back: Wood - 1-1/2" x 3-1/2" x 24"
- 2. Front: Wood - 3/4" x 3-3/8" x 12-1/2"
- 3. Inner Top: Wood - 1-1/2" x 3-1/2" x 8-3/8"
- 4. Top: Wood - 3/4" x 9-1/4" x 13"
- 5. Sides: Lap Siding - 10-1/4" x 2-3/4" x 17-1/2" x 14-3/8"  
Two sides are required.
- 6. Bottom: Wood - 1-1/2" x 3-1/2" x 3"
- Nails: 26 required



# The "K" Bluebird Nest Box

By Terry Glanzman/Modified by Roy Lukes

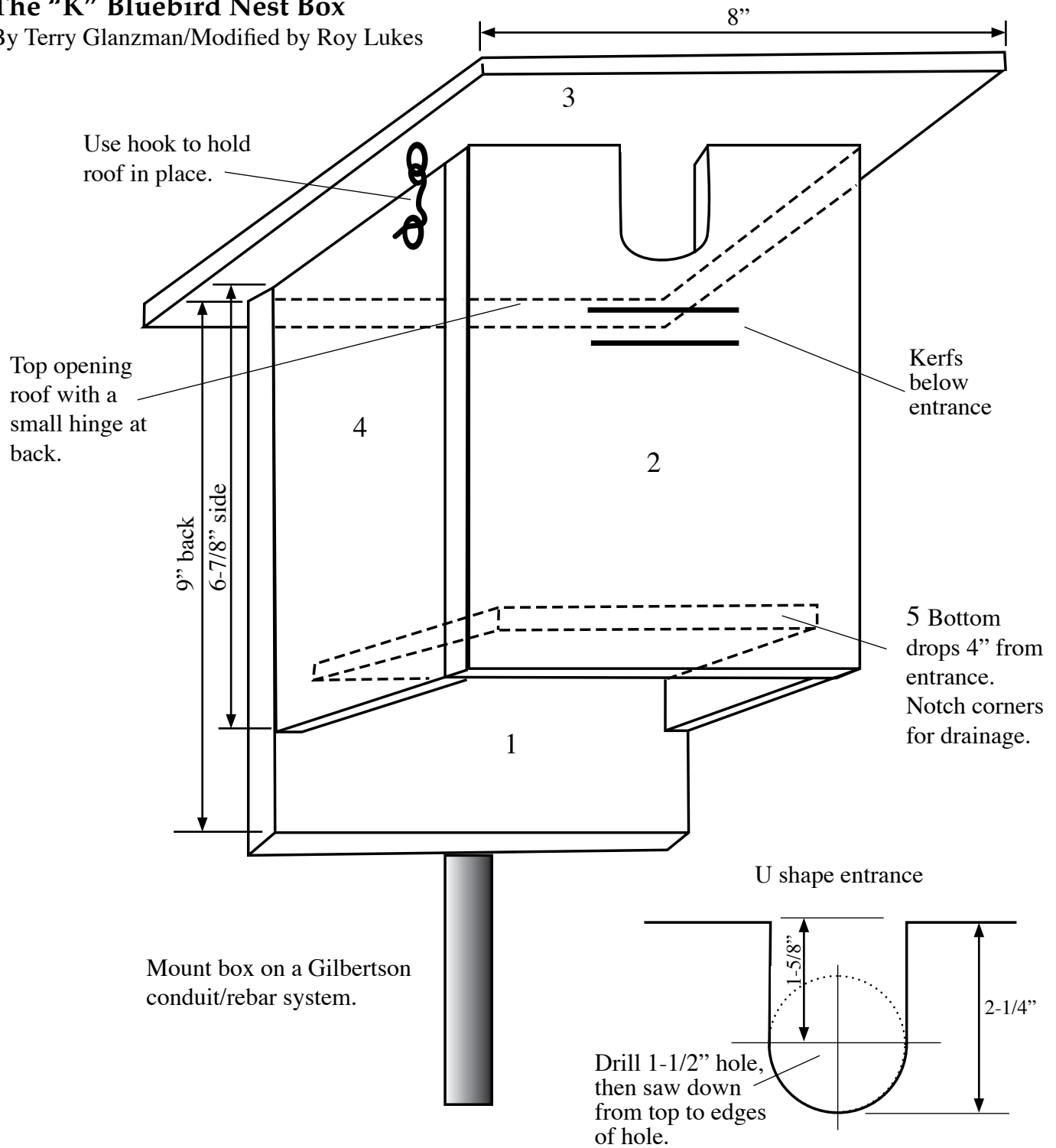

## Materials List

1. Back: 9" x 5-1/2" x 3/4"
2. Front: 7" x 5-1/2" x 3/4"
3. Top: 8" x 8-1/2"
4. Sides(2): 7" x 4-1/2" x 6-7/8"
5. Bottom: 4" x 4"

The "K" box features that make it less attractive to House Sparrows are:

- shallow box, discourages domed nest
- oblong opening set flat against roof
- no ventilation slot/holes
- the roof has a backward tilt

Some members have found this design to be 75% effective where House Sparrows are a problem. As always, monitoring is a must for best control of sparrows.

## Wisconsin Bluebird Subscription and BRAW, Inc. Membership

The Bluebird Restoration Association of Wisconsin, Inc. (BRAW) is Wisconsin's voice for bluebird conservation. BRAW publishes a quarterly newsletter, *Wisconsin Bluebird*, to share in its pages both success and failure stories by its members and other authors working to increase local bluebird populations.

BRAW stresses: How to recognize bluebird habitat; how to place nest boxes on a bluebird trail; why and how to monitor a bluebird trail; how to spot natural enemies of bluebirds, how to defend bluebirds against their enemies; identifying nest failures and what to do; the impact and significance of other bird species that may nest in bluebird houses; a statewide network of county coordinators who assist local residents with bluebird problems; the importance of local bluebird workshops; safe bluebird nest box construction; where to obtain supplies, boxes and books; report of annual bluebird population trends; bluebird videotape and movie educational services; and, an annual autumn State Convention with the attendant good fellowship of friends and families.

*Please take a few minutes to renew your membership or to become a new member of BRAW today. BRAW needs your membership support to continue the bluebird recovery program.*

BRAW is a nonprofit organization incorporated under the laws of the State of Wisconsin. Your membership donation and other financial support of BRAW, Inc. is a tax-deductible charity to the extent allowable by law (recognized by the IRS as a 501(c)(3) organization).

**Yes! I would like to join/renew my membership with the Bluebird Restoration Association of Wisconsin, Inc. and receive its newsletter *Wisconsin Bluebird*. Enclosed is my check/money order (do not send cash) made out to BRAW, Inc. for the following:**

Subscription/Membership contribution: <input type="checkbox"/> \$15 Individual <input type="checkbox"/> \$25 Family Annual <input type="checkbox"/> \$300 Life Membership <input type="checkbox"/> \$100 Corporate Annual	<input type="checkbox"/> \$15 to nest box construction with post & predator guard <input type="checkbox"/> \$100 for nest box trail <input type="checkbox"/> In addition to my membership contribution, I wish to contribute: \$ _____ <i>(Contributions to BRAW are tax deductible)</i>
Print clearly Name: _____ Address: _____ City: _____ State: _____ Zip Code: _____ Email Address: _____ Telephone: (    ) _____ County of residence: _____	Check appropriate boxes: <input type="checkbox"/> This is a renewal. <input type="checkbox"/> This is a new subscription <input type="checkbox"/> This is a GIFT subscription. Enclosed please find my check \$ _____
Mail this membership/subscription request to: BRAW, Inc. c/o Sue Schultz 5221 Cheryl's Dr. Plover, WI 54467	

Please note: This form appears as a convenience for all who wish to obtain membership. Membership renewals are due as of January 1 each year. The BRAW, Inc. bylaws stipulate that the winter issue (December issue) of *Wisconsin Bluebird* newsletter of the new year will be the last issue sent if your membership is not renewed before the Spring issue is printed.

P.S. I would like further information about volunteering for BRAW as a:		
{ } Director	{ } Officer	{ } Trail Monitor
{ } County Coordinator	{ } Assistant County Coordinator	{ } Donor of nest box lumber, etc.
{ } Writer	{ } Photographer	{ } Other: _____

**Contributions to BRAW, Inc. are tax deductible**



## 2009 BRAW Elected & Appointed Officers

**President Joe Schultz**, 5221 Cheryl's Dr., Plover, WI 54467 • 715/341-5521 joeschultz@coredcs.com (term to 12/09)

**Vice President Dr. Kent Hall**, 200 Pine Bluff Rd., Stevens Point, WI 54481 • 715/344-8081 kentsue@charter.net (term to 12/09)

**Treasurer, Mike Helgren**, 1013 Georgetown Circle, Beaver Dam, WI 53916 • 920-885-4050 mhelgren@charter.net (term to 12/09)

**Secretary Patricia Heiden**, W399 S5484 Hwy Z, Dousman, WI 53118 • 262/495-8595 brdbndr@centurytel.net. (term to 12/10)

**Director Fred Craig**, 807 Judith Ct. Holmen, WI 54636 • 608/526-2221 fm266@centurytel.net (term to 12/09)

**Director Terry Glanzman**, W6750 Hemlock Rd., Mondovi, WI 54755 • (715) 875-4771 (term to 12/10)

**Sherman Griffin**, retired

**Director, Sue Hall**, 200 Pine Bluff Rd., Stevens Point, WI 54481 • 715/344-8081, kentsue@charter.net (term to 12/09)

**Director Ellen Lafouge**, 9154 N. Fielding Rd., Bayside, WI 53127 • 414/352-6697; wibluebird@gmail.com (term to 12/10)

**Director Leif Marking**, W7917 Co. Hwy. ZB, Onalaska, WI 54650 • 608/781-0323 • cmarking@centurytel.net (term to 12/09)

**Director Patrick Ready**, 1210 Oakwood Ct., Stoughton, WI 53589 • 608/873-1703 • pready@tds.net (term to 12/09)

**Claire Romanak**, 7175 Nehrbass Rd.; Athens, WI 54411; 715-257-1905; ribriver2@wildblue.net (Term to 12/10):

**Director, Jerry Schoen**, 682 Foxglove Lane, White-water, WI 53190 • 262-473-7189 • basketsandbirds@charter.net (term to 12/10)

**Director, Toni Wanserski**, 7315 Hwy. 66, Custer, WI 54423 • pat\_toni@charter.net (term to 12/10)

### APPOINTED OFFICERS AND COMMITTEE CHAIRPERSONS:

**Data Collection and Analysis: Dr. Kent D. Hall**, Coordinator, 200 Pine Bluff Rd., Stevens Point 54481 • 715/344-8081 kentsue@charter.net;

**Data Analysis: Dr. Peter Dunn**, Associate Professor, Dept. of Biology, UW-Milwaukee, P.O. Box 413, Milwaukee 53201 • 414/229-2253; pdunn@uwm.edu

**County Coordinator Chair: Joe Schultz** (see above)

**Funding: Mike Helgren** (see above)

**WI Bluebird Editor: Patrick Ready**, (see above)

**Membership: Sue Schultz**, 5221 Cheryl's Dr., Plover, WI 54467 • 715/341-5521 • sueschultz@coredcs.com

**Nest Box Designs: Leif Marking**, (see above)

**Public Relations: Ellen Lafouge**, (see above)

**Student and Youth Outreach Committee:**

**Co-Chairpersons: Lowell Peterson**, 1860 45th St., Somerset, WI 54025 • 715/247-3243; and, Mary Holleback, 720 Madison St., West Bend, WI 53095-4136 • 262/335-9843

**Ornithological Consultants (Volunteers) Dr. Peter Dunn**, Biology Dept., UM-Milwaukee, P.O. Box 413, Milwaukee, WI 53201 • 414/229-2253

pdunn@uwm.edu and **Dr. Linda Whittingham**, Biology Dept., UM-Milwaukee, P.O. Box 413, Milwaukee, WI 53201 • 414/229-2252 whitting@uwm.edu

## Resources for bluebirders

### County Coordinators are Ready to Help You

Once each year, *Wisconsin Bluebird* newsletter publishes a list of BRAW county coordinators to help the public locate their local bluebird program contact person. You can also find them listed on [www.braw.org](http://www.braw.org).

Some BRAW county coordinators conduct one or more late winter or spring bluebird workshops that are publicized locally. Most bluebird workshops are informational. A movie, slide show or videotape may be shown, samples of nest boxes are displayed, bluebird literature and data recording forms are on hand, and questions are answered.

BRAW county coordinators are your source for BRAW forms, although many people now photocopy the more common forms that are printed in the pages of this booklet. BRAW also prints these forms in the *Wisconsin Bluebird* newsletter throughout the year.

### Where to buy nest boxes

The following vendors offer nest boxes and traps for sale. **Listing here does not imply endorsement or knowledge by BRAW, Inc. of quality of workmanship of these boxes, etc.** Call, write or email the vendor for materials used, box cost, shipping cost, etc. Prices and shipping costs are subject to change without notice.

**Peterson Nest box  
Morgan Woodworking  
304 Saint Rose Road  
Cuba City, WI 53807  
Ph. 608/744-8798  
tcmorgan@mhtc.net**

**Peterson Bluebird Houses  
Don Klecker Bluebird Houses  
N4593 – 810<sup>th</sup> St.  
Ellsworth, WI 54011  
Call 715/792-5277 after 5 p.m. or leave message.**

**PVC Gilbertson  
Steve Gilbertson  
35900 Dove St.  
Aitkin, MN 56431  
Ph. 218/927-1953  
[www.gilbertsonnestbox.com](http://www.gilbertsonnestbox.com)**

### School and Youth Outreach

Want to help expand bluebird populations and promote environmental awareness among young people?

Consider contacting your local school principal about a program sponsored by BRAW. This program encourages school and youth groups to establish and monitor a bluebird trail. A trail can be as small as a few nest boxes or dozens. The School and Youth Outreach Committee will provide the BRAW Informational Packet (which you are now reading) to the interested group, which will help them get started.

A packet can be requested from Lowell Peterson, 1860 45<sup>th</sup> St., Somerset, WI 54025.

### Recommended Reading

*The Bluebird Monitor's Guide to Bluebirds and Other Small Cavity Nesters* by Jack Griggs, Kieth Kridler, Cynthia Berger HarperResource Publishers 128 pages, ©2001. (Paperback)

Gowaty, P.A. and J.H. Plissner. 1998. *Eastern Bluebird (Sialia sialis)*. In *The Birds of North America*, No. 381 Poole and F. Gill, eds.). The Birds of North America, Inc., Philadelphia.

Zeleny, L.W. 1976. *The Bluebird*. How you can help its fight for survival, Indiana University Press, Bloomington. 170 pages. This publication is out of print but is worth looking for in a public library.

Grussing, D. *How to Control House Sparrows*. Roseville Publishing House, Roseville, Minnesota. Send \$3.50 to BRAW, 4303 Timber lane, Rhinelander, WI 54501 to receive the booklet, *How to Control House Sparrows*. Mention the booklet by name.

For more information about bluebirds go to:  
[www.braw.org](http://www.braw.org)



# Bluebird chick development

- first 14 days

by Jack Bartholmai & Pat Ready

This series of images uses "wing development" as an aid in age estimation. Conditions such as food supply, temperature, number of siblings and other factors might alter the development time a +/- of at least one day for each image after day one. When chicks first hatch they are naked, eyes are closed and they barely can raise their head but they are able to open their mouths to be fed. Between the 5th and 10th day the chicks are most vulnerable to cold temperatures when the female stops brooding them. If they get too chilled and listless they won't raise their heads when the adult birds bring them food and may starve. Both adults may stop feeding them and abandon the nest if they don't respond. Monitoring should stop after the 12th day to prevent premature fledging. Normally by the 18th day they are fledged.



All photos by Jack Bartholmai



## Bluebird Restoration Association of Wisconsin

Sue Schultz, Membership Chair  
5221 Cheryl's Dr.,  
Plover, WI 54467  
www.braw.org

©2008 BRAW

